

# General Tolerances/Allg.Toleranzen DIN

## ISO2768-mk

$0.5 \leq 3$	$>3 \leq 6$	$>6 \leq 30$	$>30 \leq 120$	$>120 \leq 400$
$\pm 0.1$	$\pm 0.1$	$\pm 0.2$	$\pm 0.3$	$\pm 0.5$

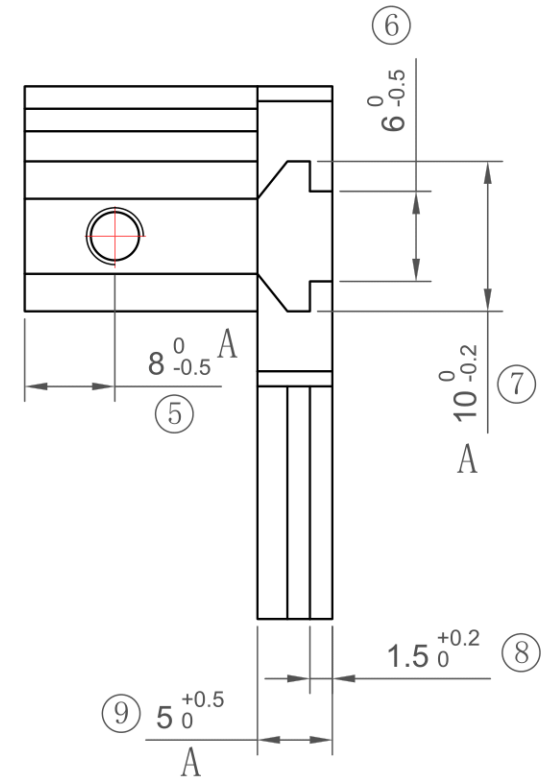
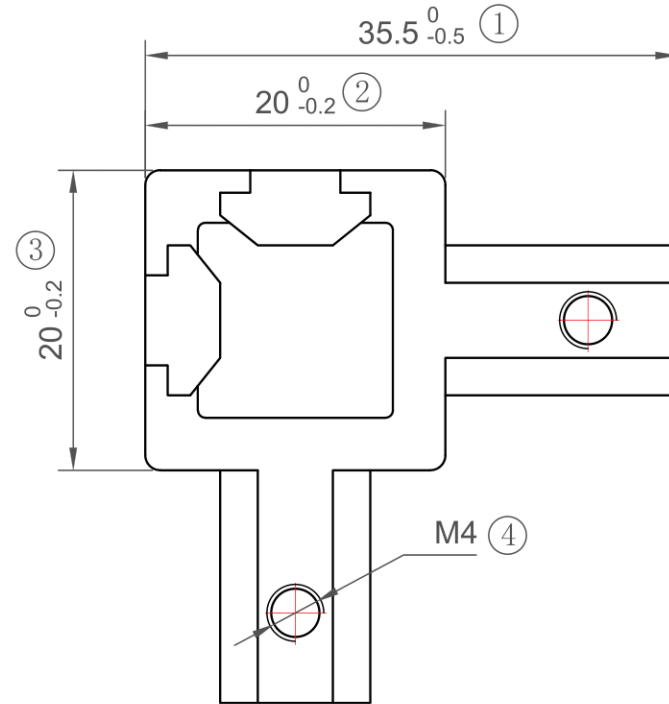
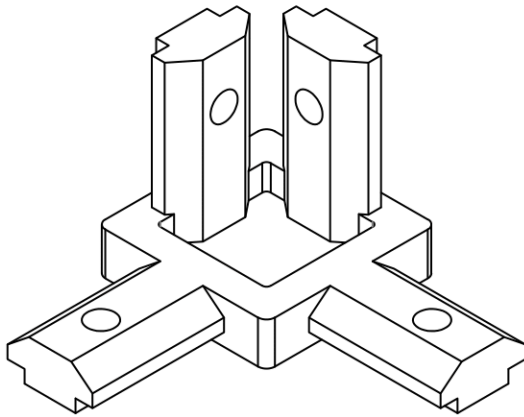

1. Material: Zinc Alloy;
2. Surface treatment: Silver spray paint;
3. Appearance should be without lack materials, smudge and burs;
4. Unspecified length tolerance according to 2768-M intermediate tolerance